

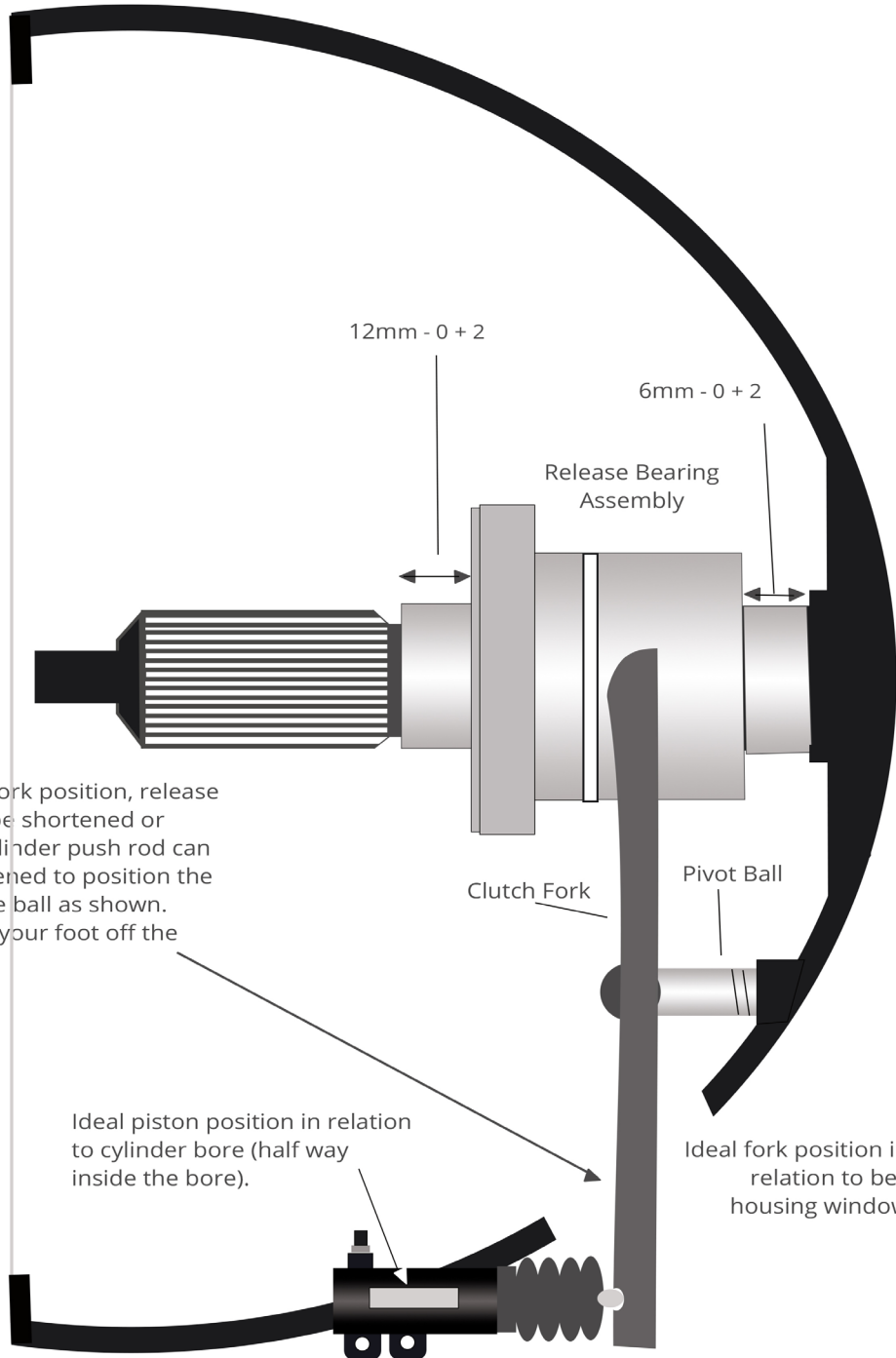

# Ideal Clutch Fork Position



To achieve the optimum fork position, release bearing or pivot ball can be shortened or lengthened. The slave cylinder push rod can also be shortened or lengthened to position the piston in the middle of the ball as shown. This example is based on your foot off the clutch pedal.